

VI TELEFILTER**Filter Specification****TFS 434****1/5****Measurement condition**

Ambient temperature: 23 °C
 Input power level: 0 dBm
 Terminating impedances at f_C *: input: 84 Ω // -5,40 pF
 output: 84 Ω // -5,40 pF

Characteristics**Remark:**

Reference level for the relative attenuation a_{rel} of the TFS 434 is the minimum of the pass band attenuation a_{min} . The minimum of the pass band attenuation a_{min} is defined as the insertion loss a_e . The centre frequency f_C is the arithmetic mean value of the upper and lower frequencies at the 3 dB filter attenuation level relative to the insertion loss a_e . The nominal frequency f_N is fixed at 434 MHz without tolerance. The given values for the relative attenuation a_{rel} and for the group delay ripple have to be reached at the frequencies given below even if the centre frequency f_C is shifted due to the temperature coefficient of frequency TC_f in the operating temperature range and due to a production tolerance for the centre frequency f_C .

D a t a		typ. Value	Limit
Insertion loss (Reference level)	a_e	2,60 dB	max. 3,5 dB
Nominal frequency	f_N	-	434 MHz
1 dB - bandwidth	BW	480 kHz	min. 400 kHz
Relative attenuation	a_{rel}		
f_N	$\dots\dots f_N \pm 0,2$ MHz	0,50 dB	max. 1 dB
$f_N - 1$ MHz	$\dots\dots f_N - 6$ MHz	22 dB	min. 15 dB
$f_N - 6$ MHz	$\dots\dots f_N - 20$ MHz	45 dB	min. 40 dB
$f_N - 20$ MHz	$\dots\dots f_N - 424$ MHz	63 dB	min. 45 dB
$f_N + 1$ MHz	$\dots\dots f_N + 8$ MHz	13 dB	min. 10 dB
$f_N + 8$ MHz	$\dots\dots f_N + 116$ MHz	47 dB	min. 35 dB
$f_N + 116$ MHz	$\dots\dots f_N + 566$ MHz	55 dB	min. 45 dB
Input power level		-	max. 10 dBm
Temperature coefficient of frequency TC_f**		- 0,036 ppm/K ²	-
Turn over temperature		10 °C	-
Operating temperature range		-	- 25 °C.. + 80 °C
Storage temperature range		-	- 35 °C.. + 85 °C

*) The terminating impedances depend on parasitics and q-values of matching elements and the board used, and are to be understood as reference values only. Should there be additional questions do not hesitate to ask for an application note or contact our design team.

***) $\Delta f(\text{Hz}) = TC_f(\text{ppm/K}^2) \times (\Delta T)^2 \times f_{T0}(\text{MHz})$

generated: _____

checked / approved: _____

VI TELEFILTER

Potsdamer Straße 18

D 14 513 TELTOW / Germany

Tel: (+49) 3328 4784-0 / Fax: (+49) 3328 4784-30

E-Mail: tft@telefilter.com

VI TELEFILTER reserves the right to make changes to the product(s) and/or information contained herein without notice. No liability is assumed as a result of their use or application. No rights under any patent accompany the sale of any such product(s) or information.

Construction and Pin Connection

(All dimensions in mm)

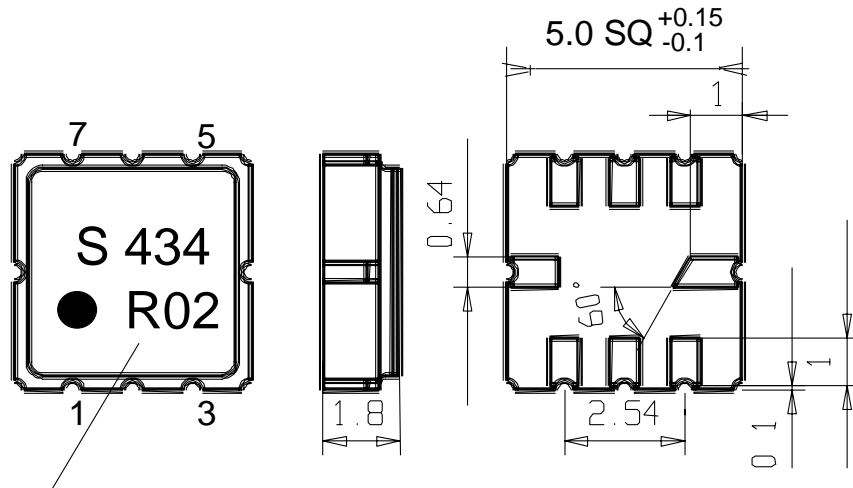
**Date code**

date code: year + week

Pin 1 Input RF Return
 Pin 2 Input
 Pin 3 Ground
 Pin 4,8 Package Ground

Pin 5 Output
 Pin 6 Output RF Return
 Pin 7 Ground

N 2001
 P 2002
 R 2003

...

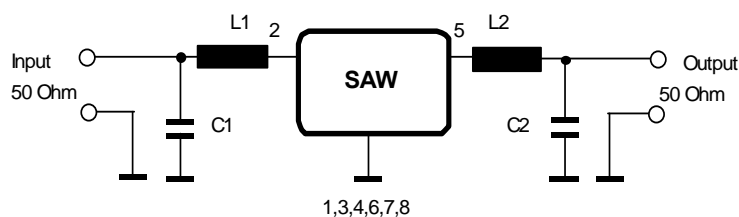
50 Ω matching circuit:**VI TELEFILTER**

Potsdamer Straße 18

D 14 513 TELTOW / Germany

Tel: (+49) 3328 4784-0 / Fax: (+49) 3328 4784-30

E-Mail: tft@telefilter.com

VI TELEFILTER reserves the right to make changes to the product(s) and/or information contained herein without notice. No liability is assumed as a result of their use or application. No rights under any patent accompany the sale of any such product(s) or information.

Stability Characteristics

After the following tests the filter shall meet the whole specification:

1. Shock: 500g, 18 ms, half sine wave, 3 shocks each plane;
DIN IEC 68 T2 - 27
2. Vibration: 10 Hz to 500 Hz, 0,35 mm or 5g respectively, 1 octave per min, 10 cycles per plan, 3 plans;
DIN IEC 68 T2 - 6
3. Change of temperature: -55 °C to 125°C / 30 min. each / 10 cycles
DIN IEC 68 part 2 – 14 Test N
4. Resistance to solder heat (reflow): reflow possible: twice max.;
for temperature conditions, please refer to the attached "Air reflow temperature conditions" on page 4;

Packing

Tape & Reel: DIN IEC 286 – 3, with exception of value for N and minimum bending radius;
tape type II, embossed carrier tape with top cover tape on the upper side;

max. pieces of filters per reel:
reel of empty components at start:
reel of empty components at start including leader:
trailer

3000
min 300 mm
min 500 mm
min 300 mm

Tape (all dimensions in mm)

W	: 12 ± 0,3
Po	: 4 ± 0,1
Do	: 1,5 + 0,1
E	: 1,75 ± 0,1
F	: 5,5 ± 0,05
G (min)	: 0,75
P2	: 2 ± 0,05
P1	: 8 ± 0,1
D1(min)	: 1,5
Ao	: 5,3 ± 0,1
Bo	: 5,3 ± 0,1
CT	: 9,5 ± 0,1

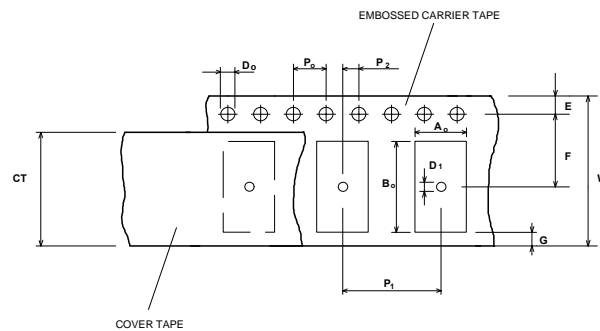
**Reel (all dimensions in mm):**

A	: 330
W1	: 12,4 + 2
W2 (max)	: 18,4
N (min)	: 50
C	: 13 +0,5 -0,2

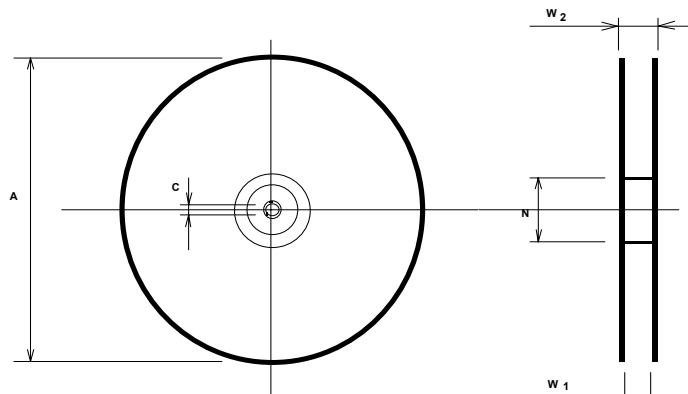

The minimum bending radius is 45 mm. The mounting surface of the filters faces the bottom side of the embossed carrier tape. Markings on the filters can be read if the upper side of the carrier tape is regarded with the sprocket holes on its right.

VI TELEFILTER

Potsdamer Straße 18

D 14 513 TELTOW / Germany

Tel: (+49) 3328 4784-0 / Fax: (+49) 3328 4784-30

E-Mail: tft@telefilter.com

VI TELEFILTER reserves the right to make changes to the product(s) and/or information contained herein without notice. No liability is assumed as a result of their use or application. No rights under any patent accompany the sale of any such product(s) or information.

Air reflow temperature conditions

1st and 2nd air reflow profile

Name:	pre-heating periods	main-heating periods	peak temperature
Temperature:	150 °C - 170 °C	over 200 °C	255 °C ± 5 °C
Time:	60 sec. - 90 sec.	20 sec. - 25 sec.	

Chip-mount air reflow profile

Table for temperature vs. time during the air reflow process

Tolerance of temperatures: ± 5 °C

time / sec.	temperature / °C	time / sec.	temperature / °C
0	23	140	160
10	34	150	161
20	46	160	164
30	60	170	170
40	80	180	180
50	103	190	205
60	121	195	230
70	134	200	255
80	143	205	230
90	150	210	205
100	154	215	180
110	156	220	165
120	158	230	140
130	159	240	120

VI TELEFILTER

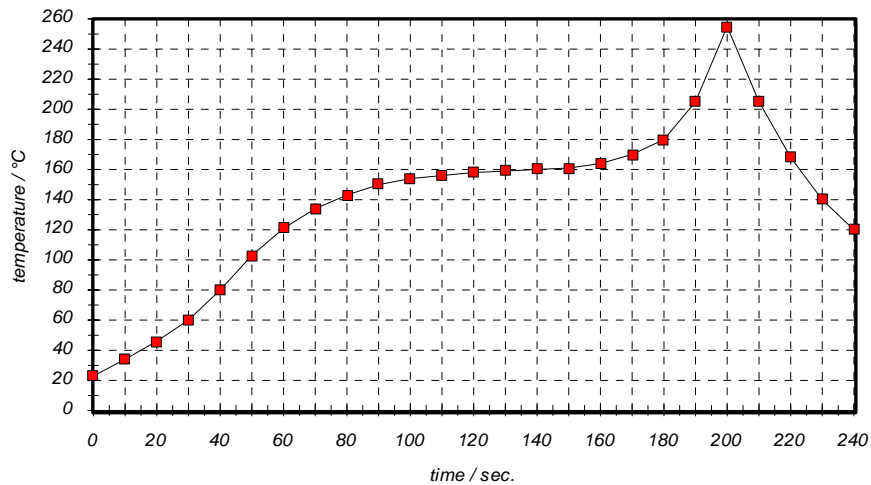
Potsdamer Straße 18

D 14 513 TELTOW / Germany

Tel: (+49) 3328 4784-0 / Fax: (+49) 3328 4784-30

E-Mail: tft@telefilter.com

VI TELEFILTER reserves the right to make changes to the product(s) and/or information contained herein without notice. No liability is assumed as a result of their use or application. No rights under any patent accompany the sale of any such product(s) or information.

VI TELEFILTER**Filter Specification****TFS 434****5/5****History**

Version	Reason of Changes	Name	Date
1.0	generate specification	Pfeiffer	13.09.2002
1.1	change 1 dB-bandwidth	Pfeiffer	20.09.2002
1.2	filter specification, add of all typical values correct of input pin	Dr. Sabah	07.01.2003

VI TELEFILTER
Potsdamer Straße 18
D 14 513 TELTOW / Germany
Tel: (+49) 3328 4784-0 / Fax: (+49) 3328 4784-30
E-Mail: tft@telefilter.com

VI TELEFILTER reserves the right to make changes to the product(s) and/or information contained herein without notice. No liability is assumed as a result of their use or application. No rights under any patent accompany the sale of any such product(s) or information.