

VI TELEFILTER**SAW Filter Specification****TFS 360C - 1/4****Measurement condition**

Ambient temperature: 23 °C
 Input power level: 0 dBm
 Terminating impedances at f_c :
 Input: $440 \Omega \parallel -1.15\text{pF}$
 Output: $440 \Omega \parallel -1.15\text{pF}$
 External coupling coil: 98 nH

Construction and pin configuration

see page 2

Characteristics**Remark:**

Reference level for the relative attenuation a_{rel} of the TFS 360 C is the minimum of the pass band attenuation a_{min} . The minimum of the pass band attenuation a_{min} is defined as the insertion loss a_e . The centre frequency f_c is the arithmetic mean value of the upper and lower frequencies at the 1.5 dB filter attenuation level relative to the insertion loss a_e . The nominal frequency f_N is fixed on 360 MHz without tolerance.

D a t a		typ. value	tolerance/limit
Insertion loss (Reference level)	$a_e = a_{min}$	-	max 5,0 dB
Nominal frequency	f_N	-	360,0 MHz
Centre frequency	f_c	360,0 MHz	
Pass band ripple $f_N \pm 67,7\text{kHz}$	BW	-	max 1,5 dB
Relative attenuation	a_{rel}		
$f_N \pm 0,4 \text{ MHz} \dots f_N \pm 0,6 \text{ MHz}$		-	min 27 dB
$f_N \pm 0,6 \text{ MHz} \dots f_N \pm 0,8 \text{ MHz}$		-	min 42 dB
$f_N \pm 0,8 \text{ MHz} \dots f_N \pm 1,6 \text{ MHz}$		-	min 50 dB
$f_N \pm 1,6 \text{ MHz} \dots f_N \pm 3,0 \text{ MHz}$		-	min 45 dB
$f_N \pm 3,0 \text{ MHz} \dots f_N \pm 115 \text{ MHz}$		-	min 52 dB
Group delay ripple $f_N \pm 67,76 \text{ kHz}$	GD	-	max 2,0 μs
Input power level		-	max 10 dBm
Operating temperature range		- 20 °C ... + 75 °C	
Storage temperature		-35 °C ... + 85 °C	
Temperature coefficient of frequency (T_{c_f}) *		- 0.036 ppm/K ²	
Frequency inversion temperature		+ 20 °C	

*) $\Delta f_C(\text{Hz}) = T_{c_f}(\text{ppm/K}^2) \times (T - T_A)^2 \times f_{CAT}(\text{MHz})$

Generated:**Checked / approved:**

_ VI TELEFILTER
 Potsdamer Straße 18
 D 14 513 TELTOW / Germany
 Tel: (+49) 3328 4784-52 / Fax: (+49) 3328 4784-30
 E-Mail: tft@telefilter.com

Vectron International Inc.
 267 Lowell Road
 Hudson, NH 03051 / USA
 Tel: (603) 598-0070 Fax: (603) 598-0075
 E-Mail: vti@vtinh.com

VI TELEFILTER reserves the right to make changes to the product(s) and/or information contained herein without notice. No liability is assumed as a result of their use or application. No rights under any patent accompany the sale of any such product(s) or information.

Construction and pin configuration
(All dimensions in mm)

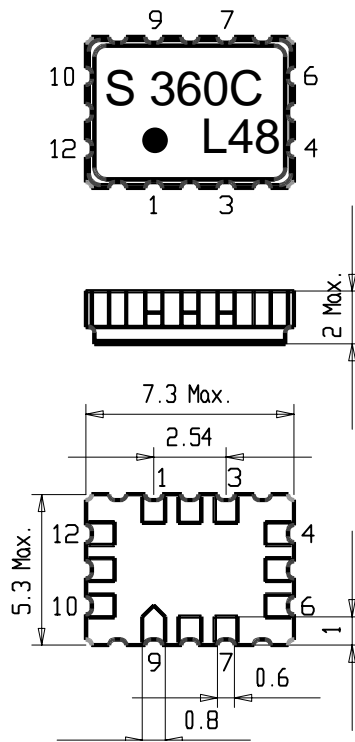

- 1 Output
- 2 Output
- 3 Ground
- 4 ext. Coil
- 5 Ground
- 6 Ground
- 7 Input
- 8 Input
- 9 Ground
- 10 Ground
- 11 Ground
- 12 Ground

50 Ohm Test circuit 1

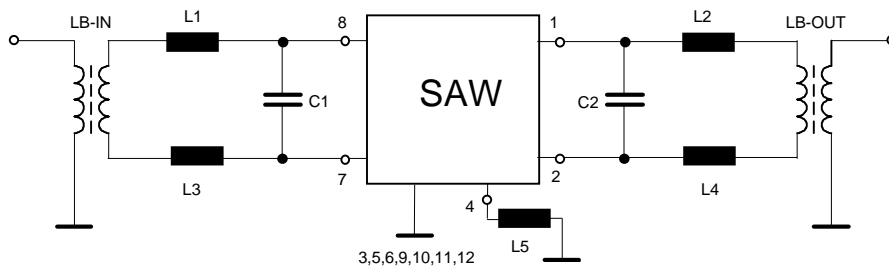

50 Ohm Test circuit 2

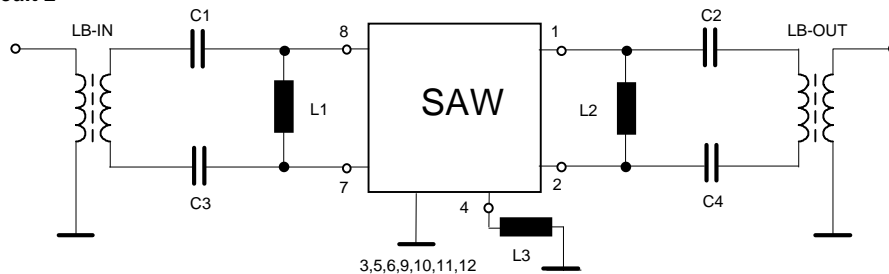

Stability characteristics

After the following tests the filter shall meet the whole specification:

1. Shock: 500g, 18 ms, half sine wave, 3 shocks each plane;
DIN IEC 68 T2 - 27
2. Vibration: 10 Hz to 500 Hz, 0,35 mm or 5g respectively, 1 octave per min, 10 cycles per plan, 3 plans;
DIN IEC 68 T2 - 6
3. Damp heat: 25 °C to 55°C / 95% r.H. / 10 cycles
(cycle) DIN IEC 68 - 2 - 30 Db
4. Resistance to solder heat (reflow): max. 2 times reflow process;
for temperature conditions refer to the attached "Air reflow temperature conditions" on page 4;

Packing

Tape & Reel: IEC 286 - 3, with exception of value for N and minimum bending radius;
tape type II, embossed carrier tape with top cover tape on the upper side;
max. pieces of filters per reel: 3000
Reel of empty components at start: min 300 mm
Reel of empty components at start including leader: min 500 mm
Trailer min 300 mm

Tape (all dimensions in mm)

W	: 16 ± 0,3
Po	: 4,0 ± 0,1
Do	: 1,5 + 0,1
D1	: 1,5 + 0,5
E	: 1,75 ± 0,1
F	: 7,5 ± 0,1
G (min)	: 0,60
P2	: 2,0 ± 0,1
P1	: 8,0 ± 0,1
D1(min)	: 1,5
Ao	: 5,5 ± 0,1
Bo	: 7,5 ± 0,1

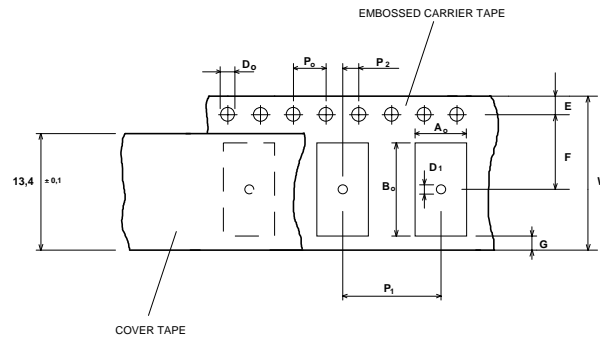
**Reel (all dimensions in mm):**

A	:	330
W1	:	16,4 +2
W2 (max)	:	22,4
N (min)	:	>= 50
C	:	13,0 +0,5/-0.20 ^A

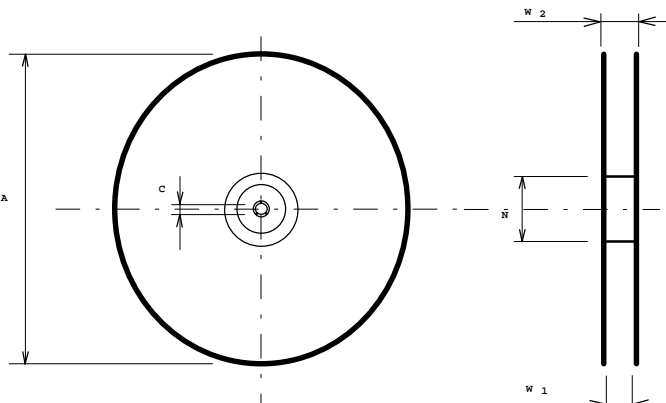

The minimum bending radius is 45 mm. The mounting surface of the filters faces the bottom side of the embossed carrier tape. The marking of the filters is able to read if the view is directed on the upper side of the carrier tape with the sprocket holes on the right side of the tape.

Air reflow temperature conditions

1st and 2nd air reflow profile

Name:	pre-heating periods	main-heating periods	peak temperature
Temperature:	150 °C - 170 °C	over 200 °C	255 °C ± 5 °C
Time:	60 sec. - 90 sec.	20 sec. - 25 sec.	

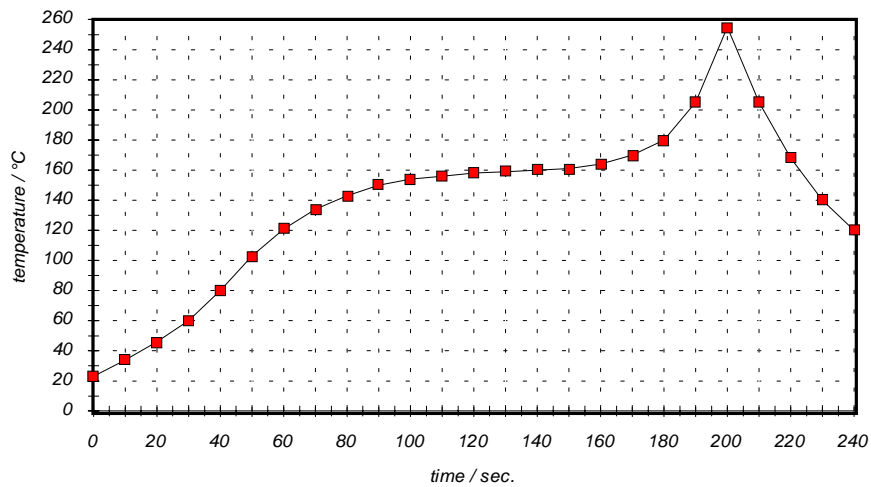
Chip-mount air reflow profile

Table for temperature vs. time during the air reflow process

Tolerance of temperatures: ± 5 °C

time / sec.	temperature / °C	time / sec.	temperature / °C
0	23	140	160
10	34	150	161
20	46	160	164
30	60	170	170
40	80	180	180
50	103	190	205
60	121	195	230
70	134	200	255
80	143	205	230
90	150	210	205
100	154	215	180
110	156	220	165
120	158	230	140
130	159	240	120